

STROH

DIAMANTWERKZEUGE

Diamond Roller Dressers
Diamond Roller Truers

Diamond roller dressers are the top high-tech products of an outstanding and creative company.



The surface of a galvanic negative (GN type) plated STROH ROLLER DRESSER with statistical diamond grain distribution. On request with hand set strong edges (GNS type).



The surface of a STROH ROLLER DRESSER covered by infiltrated and statistically distributed diamond grain (IS type).



For about two decades, rotating diamond tools have been evident in dressing technology. Preliminary reasons for changing to this technology were advantages as shorter dressing times, absolute form precision and longer wear. So today there is hardly any mass grinding company in industries like automotive, gear, bear, electric, hydraulic and tools that doesn't make use of diamond roller dressers and the therefrom resulting manufacturing security.

Companies like STROH DIAMOND TOOLS, who manufacture diamond roller dressers are highly aware of customers high demands: Because the profile accuracy of a grinded workpiece preliminary depends on tolerances of the diamond roller dresser, and profile mistakes can hardly be sorted out by other parameters.

For STROH DIAMOND TOOLS this is a challenge and source for success at the same time. After all, the company has been known for 50 years in the field of non-rotating dressing tools and so it is evident, that the complete know-how from this experience became part of manufacturing these high-tech diamond roller dressers.



The surface of a STROH ROLLER DRESSER covered by infiltrated and hand set diamond grain (IG type).



STROH ROLLER DRESSER for grinding the slideway of a linear motion device.



STOH ROLLER DRESSER for grinding the raceway of a ball bearing.

Our roller truers combine newest CNC-technology with the advantages of rotating diamond dressing tools.

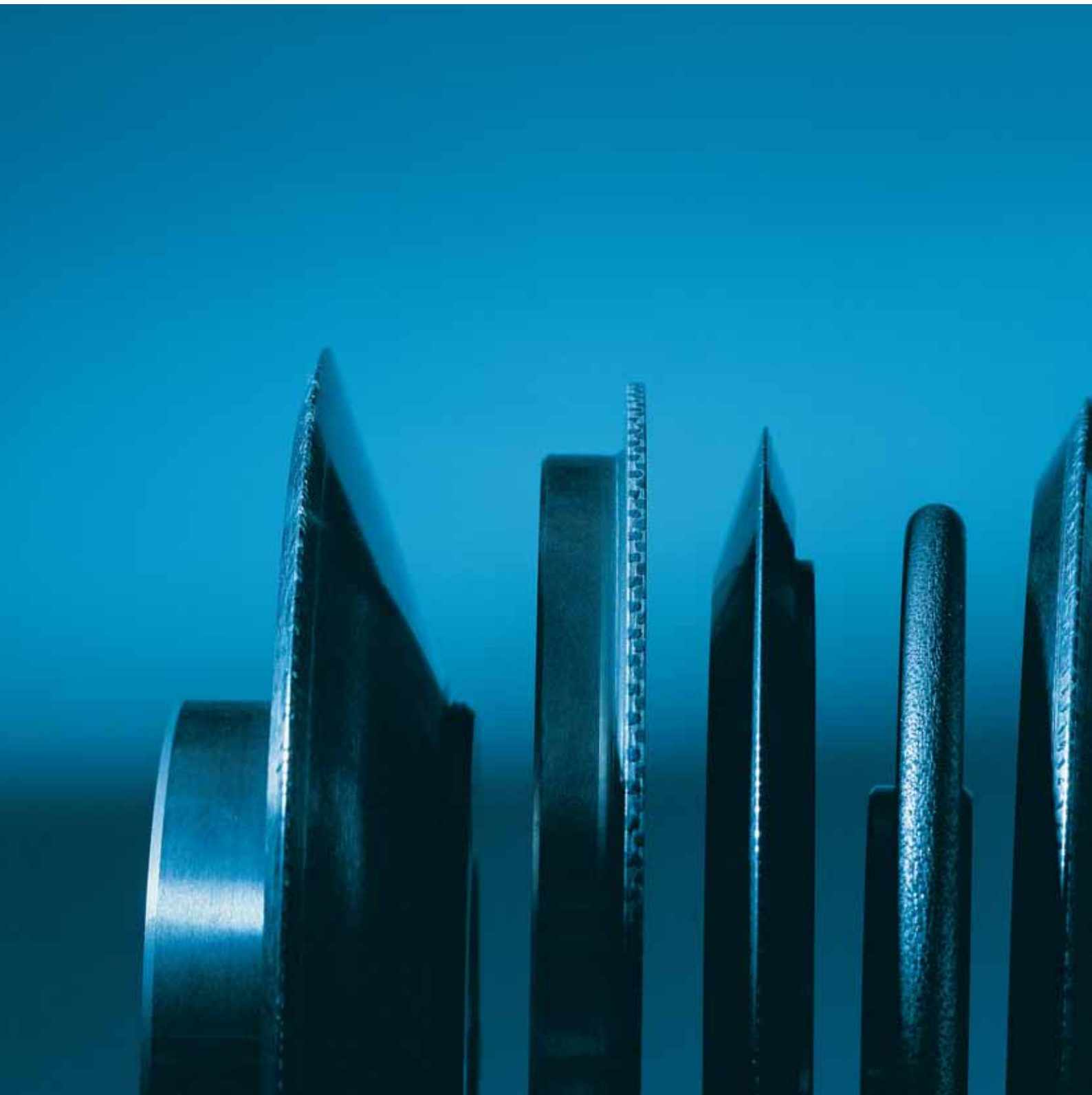



The design of the roller truer – so far the youngest product in the field of rotating diamond dressers- results from using an accurate CNC-track control at the grinding machines.

Roller truers are different from roller dressers in one specific handling detail: The truing of the grinding wheel is the result of combining the roller truer shape and its CNC-controlled move, which means, that the quality of workpiece ist determined by the quality of the roller truer as well as the CNC-program.

The profile making by CNC marks the application field of roller truers: It is the ideal dresser for the flexible manufacturing of small quantities with high recurrence rates.

The variable and universal application spectrum of the roller truers provide the great advantage, that seven types cover most applications. So the manufacturing of roller truers is rational and comparingly cheap, because there is no need for costly special makings.

By combining the components precision and CNC-control, the roller truer provides individual grinding results of highest quality standards.

Diamond Roller Truers (Standard Program) – Dimensions and tolerances

Diamond roller truer 800 11
for general truing purposes

R: 0,1 bis 1,0 mm
W: 20 bis 90 degrees
D1: max. 300 mm
D2: to be specified by user

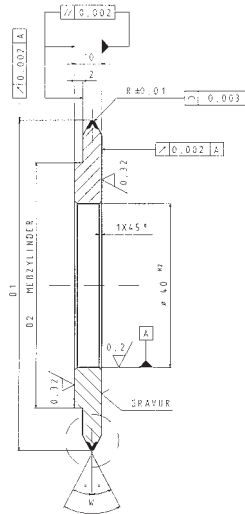

Diamond roller truer 800 14
for cylindrical fine and finest truing

F: 0,1 bis 0,8 mm
D1: max. 300 mm
D2: to be specified by user

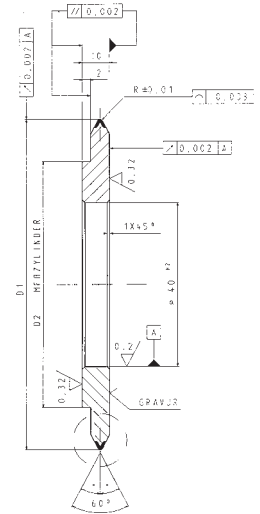
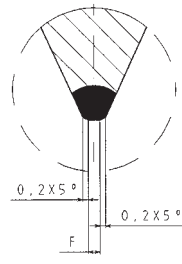

Diamond roller truer 800 10
for general truing purposes

R: 0,5 bis 3,0 mm
D1: max. 300 mm
D2: to be specified by user

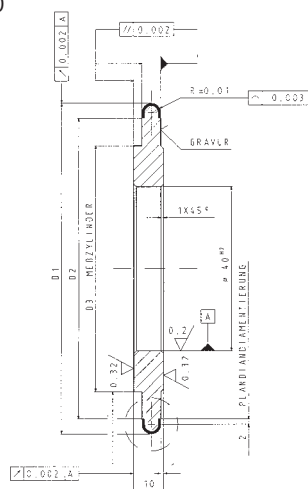
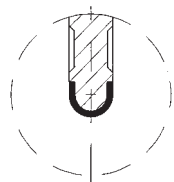

Diamond roller truer 800 12
for general truing purposes and
nose truing

R: 0,1 bis 1,0 mm
W: 30 bis 90 degrees
D1: max. 300 mm
D2: to be specified by user

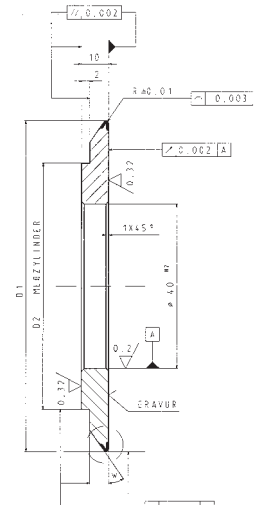

Diamond roller truer 800 13
for combined truing of cylinders,
noses and grooves

B: 2,0 bis 10,0 mm
R: 0,2 bis 2,0 mm
D1: max. 300 mm
D2: to be specified by user

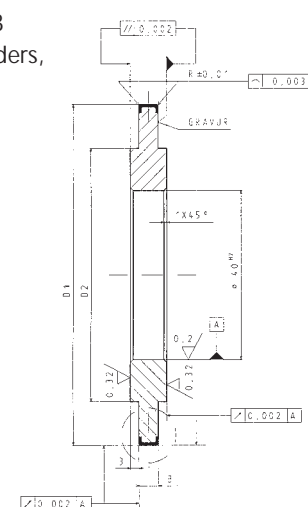
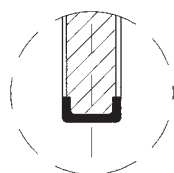

Diamond roller truer 800 15
for cylindrical rough truing
and pretruing

B1: 0,5 bis 1,5 mm
D1: max. 200 mm

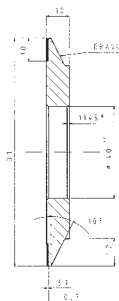

Diamond roller truer 800 16
for general purposes and
for grooves

B: 0,5 bis 3,0 mm
D1: max. 200 mm
D2: to be specified by user

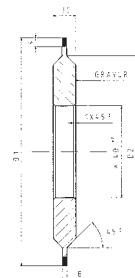

Diamond Roller Dressers – Dimensions and tolerances

Body dimensions

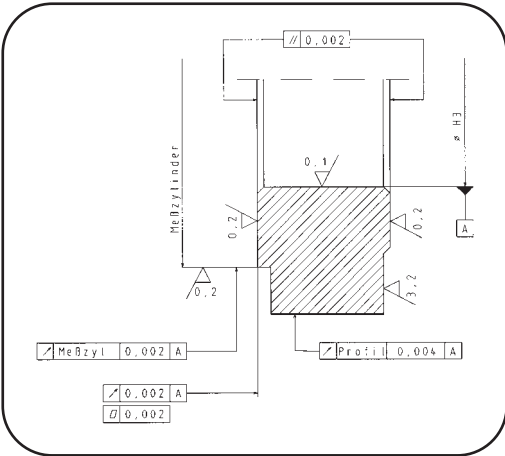

Radial and axial dimensions

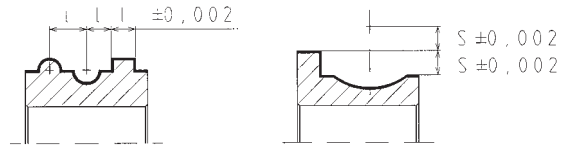

Radiuses

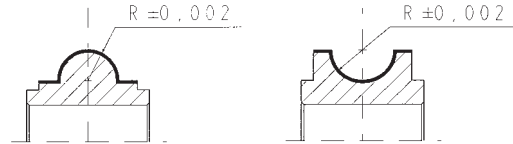

Profile dimensions

Cylindricity

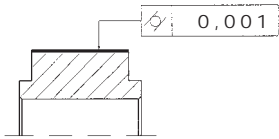

Flatness

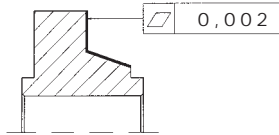

Straightness

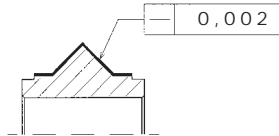

Line shape

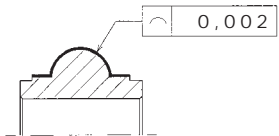

Angles

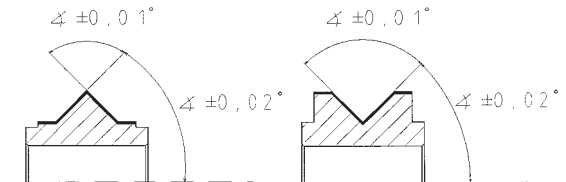

The mentioned tolerances underline the actual design standard of STROH ROLLER DRESSERS. They show the levels which are reached with the manufacturing of a GN type roller dresser. Complex profiles can be made without limitation (convex radiuses bigger than 0,1 mm, concave radiuses bigger than 0,03 mm). The high accuracy of the GN roller dresser is basically reached without an after treatment of the diamond coat. The tolerance rates of the profiles at IG- and IS-roller dressers are about one decimal place higher. In case of need specific rates can be improved by grinding over the diamond coat.





Better technology and excellent engineers
qualify us for top results.

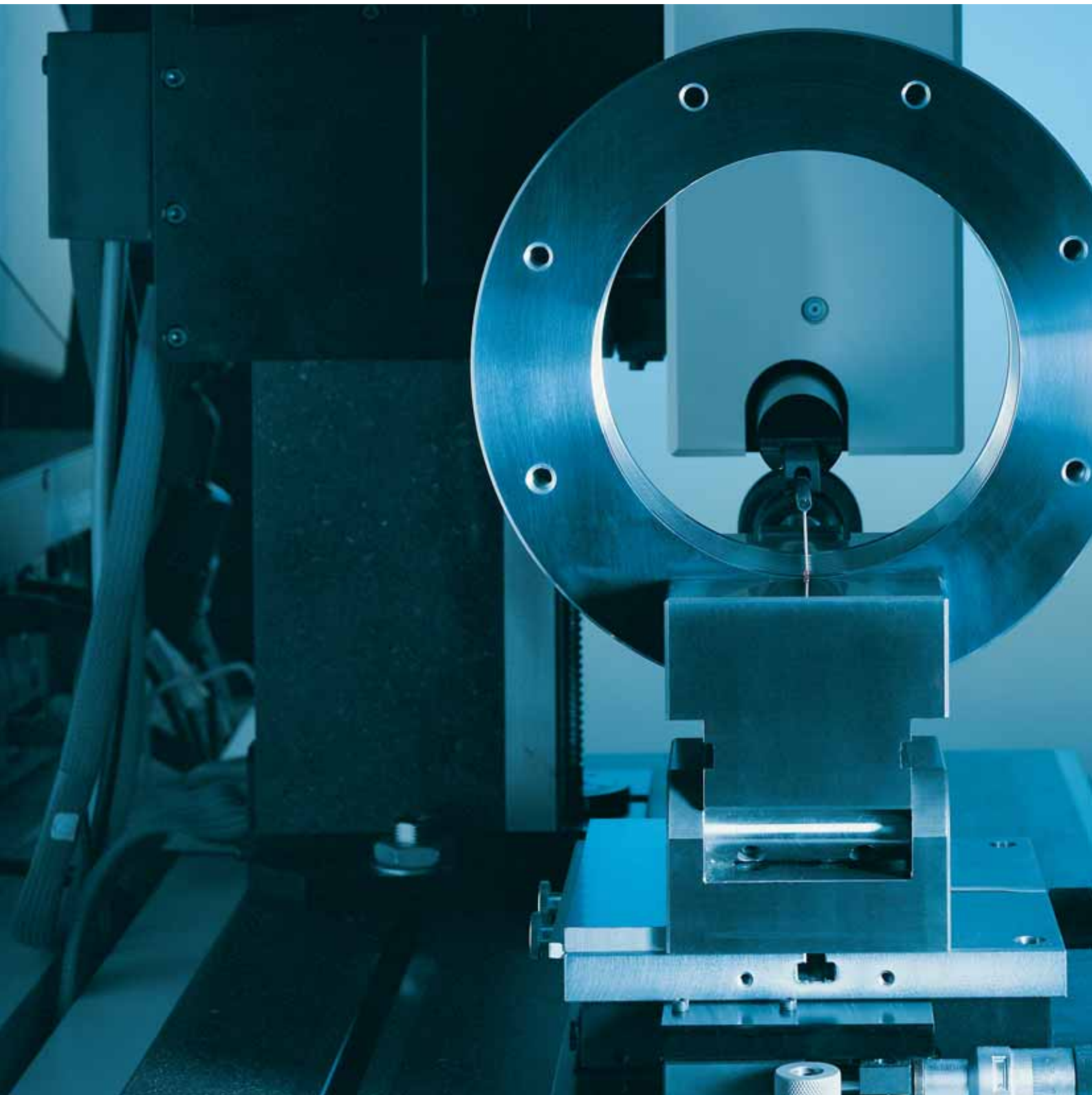



Success on a long term basis can only be reached by the manufacturer of diamond roller dressers if the first priority is given to the absolute accuracy and process control. Extensive investments and their progressive renewal rates form the basis for such a high standard, as STROH DIAMOND TOOLS represents it. The employed measuring system represents the newest level of technology available. There is our profile making, strictly done on most modern CNC-machines online controlled by CAD/CAM-computers. Of course all quality related manufacturing steps take place only in a fully temperature controlled environment.

There is our PC-network for production control, where the actual capacities of all compartments can be balanced most efficient at any time. So STROH DIAMOND TOOLS has an optimal production management and therefore shortest passing trough time.

There ist our complex quality control system. It takes the relevant figures from each production step into the central quality database.

Summarizing all investments STROH DIAMOND TOOLS never leaves out of account the factor of „human input“. So in our company first class specialists continuously work on the improvement of methods employed in producing and measuring as well as the development of new technological processes.

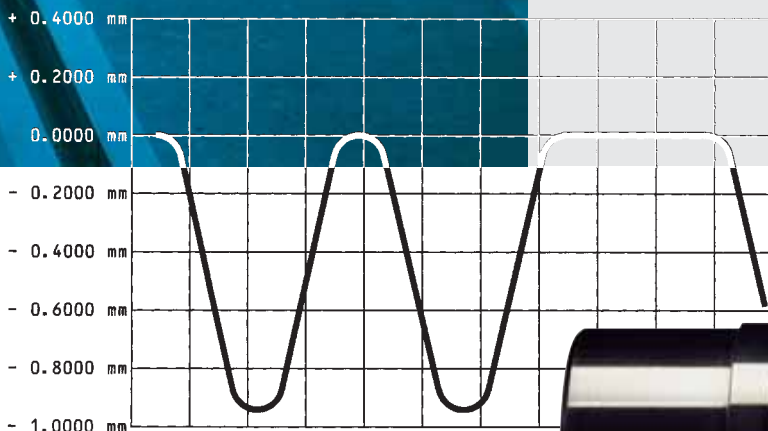

Most updated measuring systems used as an unfailable controlling body document even minimal deviations evident in reports and diagrams.

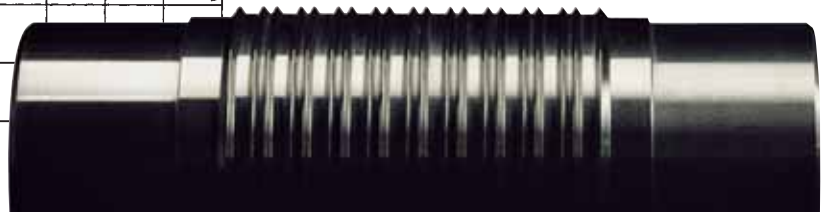

In servicing our customers we set new dimensions at the documentation of our performance.



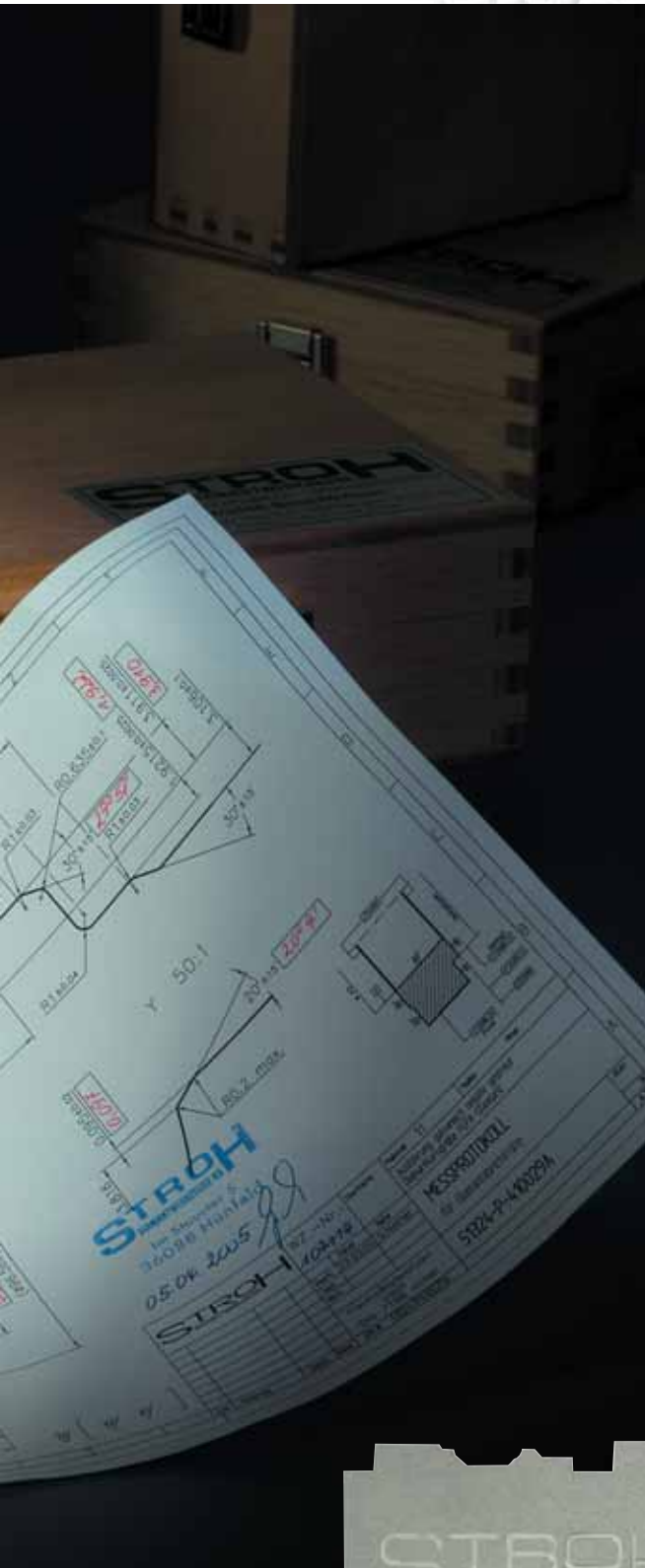

Since STROH DIAMOND TOOLS gave you a small view of its capabilities, you should put it to the test.

Providing you are already in possession of a drawing of the roller dresser or truer from a previous order, your new order can be quickly processed.

However, if a drawing is not available, our in-house design department will support your tool development. Our designers will produce the roller dresser drawing based on the workpiece drawings to be ground. In addition, our application engineers will utilise your detailed technical data of the grinding process, grinding wheel and grinding machine; these parameters provide the technical data necessary for a tool design, which ensures the highest process capability.

Comprehensive quality control documentation, which exceeds normal quality standards, is included with each roller dresser or truer supplied. In addition to the drawing of the roller dresser, we supply one profiled specimen manufactured from hardened flat or cylindrical steel. Measurement data from this specimen are documented in graphic or tabular form and can be compared to your specified nominal data. You will therefore benefit directly from our sophisticated level of data network used during our manufacturing process; each step in the production of a roller dresser is supported by our central geometric data control.

Hard facts and detached verification of the products are the basis for the solid cooperation with the users.





STROH Diamantwerkzeuge KG | Kinzigheimer Weg 2e | D-63486 Bruchköbel
Tel. 0049 6181 / 9740-0 | Fax 0049 6181 / 9740-40 | E-Mail: info@stroh-diamant.de